

**Power Supply**

: 80-230V.50-60Hz. AC / 24V DC at standby ~11 W. max. ~60 W.

**Arms**

: Single-sided Ø40mmx2,5mm anodised hard mat aluminium (Opt. 304-grade stainless steel). Can be dismantled or mounted one by one separately.

**Dimensions**

: 500x955x300 + arm length (470mm)

**Weight**

: ~36 kgs

**Body Features**

: 1,5 mm 304-grade stainless steel protected against water for external utilisation.

**Working temperature**

: -17°C/+68°C (Ops. -50°C with heater unit)

**Control System**

: Can be controlled through dry contact or any tension in between TTL. CMOS. 5-48v. Can be operated harmoniously with all kinds of access control units and token system when integrated. The functions can be controlled via RS 232, RS 485 or LAN network.

**Flow Rate**

: Passage Capacity of Mechanical unit for Manual-Version=Max. 97 passages/minute;  
Nominal=41 persons/minute  
Passage Capacity of Mechanical unit for Motorised-Version=Max. 48 passages/minute;  
Nominal=29 persons/minute  
Please note that the above given figures are approximate for one person per walkway or lane.

**Explanatory Note:** The system allows the new passage authorisation in less than 0,3 seconds. After the passage authorization, the total passage time depends on the pushing and passage speed of the persons.

Utilisation of different access control units can change the flow rate.

**Indicators**

: Direction indicators are built-in property

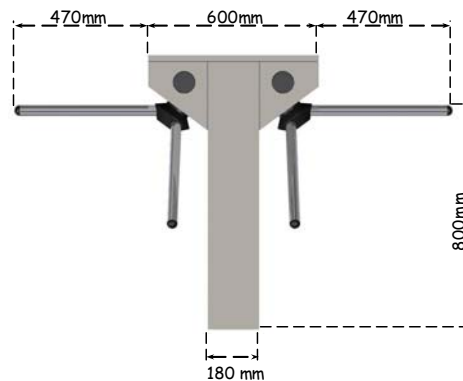
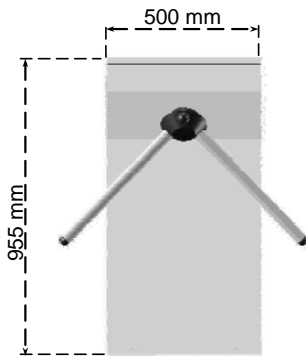
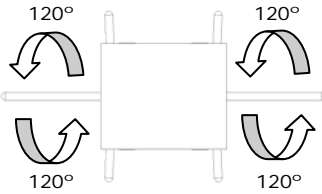

- Power Supply** : 80-230V.50-60Hz. AC / 24V DC at standby ~22 W. max. ~120 W.
- Arms** : Double-sided Ø40mmx2,5mm anodised hard mat aluminium (Opt. 304-grade stainless steel). Can be dismantled or mounted one by one separately
- Dimensions** : 500x955x600 + arm length (2x470mm)
- Weight** : ~56 kgs
- Body Features** : 1,5 mm 304-grade stainless protected against water for external utilisation.
- Working Temperature** : -17°C/+68°C (Ops. -50°C with heater unit)
- Control System** : Can be controlled through dry contact or any tension in between TTL. CMOS. 5-48v. Can be operated harmoniously with all kinds of access control units and token system when integrated. The functions can be controlled via RS 232, RS 485 or LAN network.
- Flow Rate** : Passage Capacity of Mechanical unit for Manual-Version=Max. 97 passages/minute;  
Nominal=41 persons/minute  
Passage Capacity of Mechanical unit for Motorised-Version=Max. 48 passages/minute;  
Nominal=29 persons/minute  
Please note that the above given figures are approximate for one person per walkway or lane.
- Explanatory Note:** The system allows the new passage authorisation in less than 0,3 seconds. After the passage authorization, the total passage time depends on the pushing and passage speed of the persons.  
Utilisation of different access control units can change the flow rate.
- Indicators** : Direction indicators are built-in property